

Vacuum Booster Pump

HV500, 700, 1000, 2000, 3000, 4000, 5000

Based on Success

HR Blowers are one of the world's leading air blower manufacturers and have a reputation for quality, innovation and service. The HV Series Vacuum Booster Pumps have been developed from the highly successful HR Blowers range of Roots type positive displacement air blowers, of which thousands are giving excellent service throughout the world.

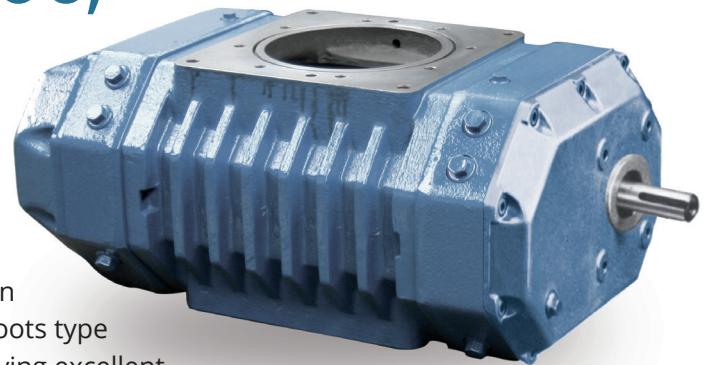

Applications

- Vacuum Packaging
- Metalizing
- Metal Casting
- Vapour Recovery
- Industrial Lasers
- Distillation
- Process Engineering
- Solvent Recovery

Design Features

- A wide range of sizes
- Compatible with all types of backing pump
- Ultimate pressure better than 5×10^{-3} millibars
- Horizontal or vertical flow
- Compact robust design
- Flange mounted motor or vee-belt drive
- 50Hz or 60Hz operation

Options

- Internally-sealed model prevents gas contamination
- Ultimate pressures better than 1×10^{-3} millibars
- Internal nickel plating provides high corrosion resistance
- Oil coolers for high temperature applications
- Inlet and outlet flange adaptors available
- Base frame option

Choice of installation arrangements

The HV range of Vacuum Booster Pumps is very adaptable in installation. Boosters can be supplied bare shaft so that a vee-belt drive can be fitted if the application demands a very precise pumping speed.

For compactness, a flange-mounted, direct-coupled electric motor can be fitted.

If pipework is sufficiently rigid, this can be used to support the unit, or alternatively it can be mounted on base rails. The choice of vertical

flow with pipe connections top and bottom, or horizontal flow with pipe connections at the sides is available.

Performance

A vacuum booster pump does not have a performance of its own. It is used to extend the performance of the backing pump with which it is combined. The performance of the combination (pumping set) depends on the characteristics of the backing pump.

An example of this is given in the diagram below, where the performance of the same HV 1000 booster pump is seen to be very different when backed by a liquid ring pump, from its performance when backed by an oil sealed vane pump. When properly matched with an appropriate backing pump, a Root type vacuum booster pump can be expected to have an actual pumping speed of between 70 and 85% of its rated maximum capacity.

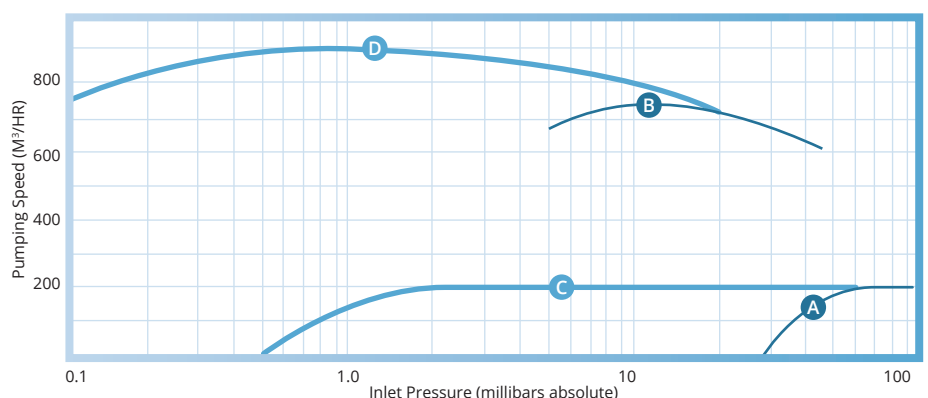
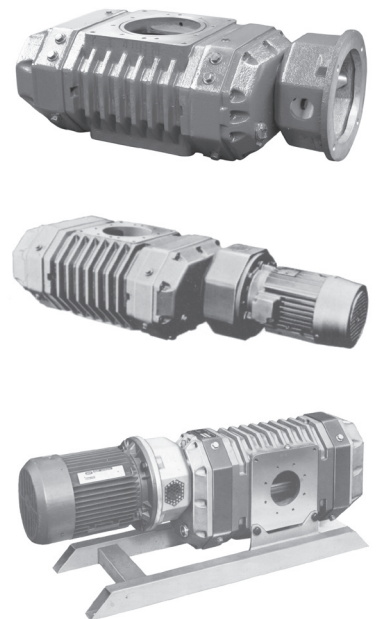

- A: Performance of liquid ring backing pump
- B: Performance of booster pump HV1000 backed by liquid ring pump
- C: Performance of oil sealed type backing pump
- D: Performance of booster pump HV1000 backed by vane type pump

NOTE: Clockwise rotation viewed on shaft end

For Horizontal Flow (as shown) Top Shaft Drive
For Vertical Flow (downwards) Right Hand Shaft Drive

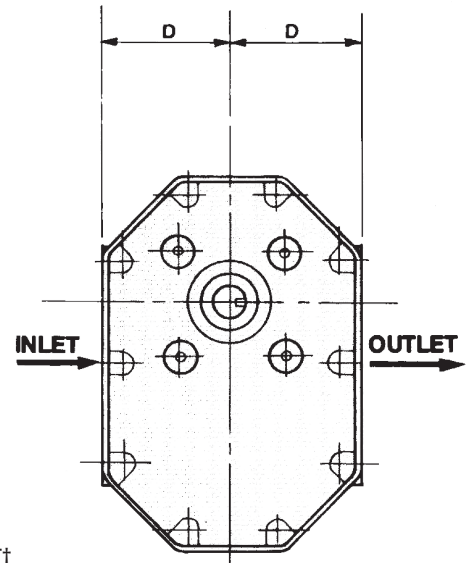
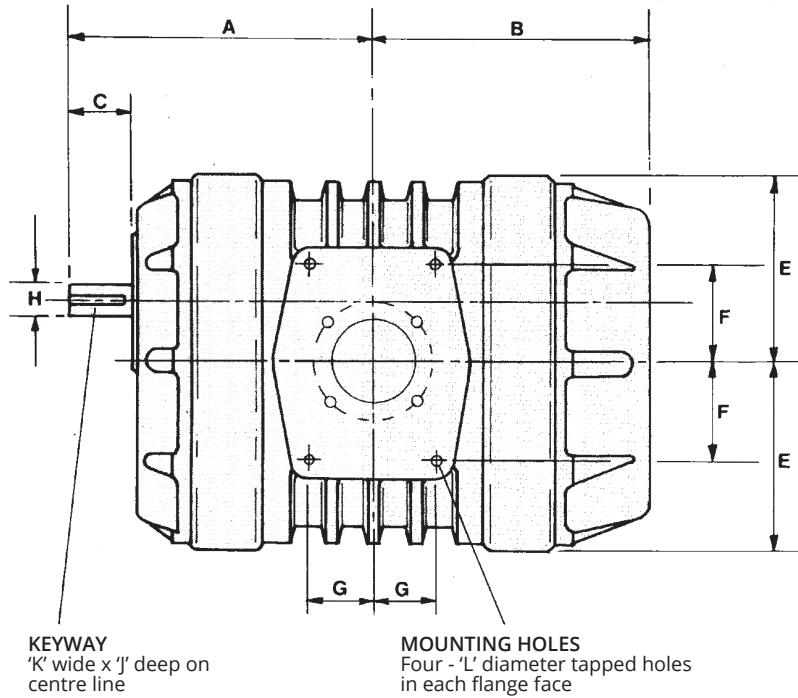

INLET†
'M' dia. bore with 'N' number of 'P' dia. tapped holes on 'Q' pitch circle dia. "off centre"

OUTLET†
'R' dia. bore with 'S' number of 'T' dia. tapped holes on 'U' pitch circle dia. "off centre"

Dimensions

All dimensions in millimetres

Booster Size	A	B	C	D	E	F	G	*H(J6)	J Nominal	K Nominal	L	M	N	P	Q	R	S	T	U
HV 500	235	220	50	110	160	75	55	28	4.0	8.0	M12	70	4	M8	110	70	4	M8	110
HV 700	260	245	50	110	160	85	55	28	4.0	8.0	M12	102	8	M8	145	70	4	M8	110
HV 1000	305	290	50	110	160	100	100	28	4.0	8.0	M12	153	8	M10	200	102	8	M8	145
HV 2000	360	340	50	135	198	100	100	28	4.0	8.0	M12	153	8	M10	200	102	8	M8	145
HV 3000	398	348	75	170	250	135	115	45	5.5	14.0	M16	153	8	M10	200	102	8	M8	145
HV 4000	468	418	75	170	250	135	135	45	5.5	14.0	M16	261	12	M10	310	153	8	M10	200
HV 5000	525	475	75	170	250	135	135	45	5.5	14.0	M16	261	12	M10	310	153	8	M10	200

Capacities

* ISO Shaft tolerance to BS4500: Part 1: 1969 † Inlet and outlet facings to ISO vacuum standard

Booster Size	*Nominal Capacity				Weight (kg)	Recommended Motor Size (kw)
	2880 RPM (50Hz)		3450 RPM (60Hz)			
	M ³ /HR	CFM	M ³ /HR	CFM		
HV 500	500	300	600	350	60	2.2
HV 700	700	400	800	470	79	3.0
HV 1000	1000	580	1200	700	98	3.0
HV 2000	2000	1150	2400	1400	163	5.5
HV 3000	3000	1750	3500	2000	250	7.5
HV 4000	4000	2300	4800	2750	290	11.0
HV 5000	5000	3000	6000	3500	315	15.0

*Capacity is approximately proportional to rotational speed. For example a 10% reduction in rpm will result in a 10% reduction in capacity
Maximum speed for all boosters is 3450rpm

For accurate performance characteristics please contact HR Blowers