

Dust-Free Vacuum System Filtration

Conair Dust Collectors keep your plant free of air-born dust and fines and prevent dust from fouling the vacuum pump.

A central vacuum dust collector allows dust filtration to take place at the floor level. An air-tight collection container makes the removal of fines quick and easy.

Automatic filter cleaning is standard, lengthening the time between service requirements. DC1 and DC2 models use an integrated "popper valve" to remove dust from the filter, while the DC3 has a sophisticated sequential blowback system.



Easy, No Tools Emptying and Servicing

The integrated dust canister releases easily for periodic emptying. A single hand knob opens the lid for quick access to the filter cartridge.

Each model comes equipped with a free standing floor frame. On models DC1 and DC2, the stand may be removed for wall-mounting. An auto-dump option is available to automatically remove collected dust or to allow open dumping into other containers.

The DC1 and DC2 are sized to provide the right amount of filter area for the pump CFM and line size of the conveying system.

The largest dust collector, the DC3, provides three filters with an automatic sequential blowback system for maximum filter life.

- ▶ **Automatic filter cleaning**
The cartridge filter releases entrained dust with each cycle.
- ▶ **Tangential air/dust inlet**
Preliminary air/dust separation takes place right at the dust collector inlet. The tangential inlet causes the air to spiral upon entry, spinning the dust free from the air.

- ▶ **Flexible**
Easy, screw-in line adapters in a wide range of sizes mean that each unit works with a variety of pumps and line sizes.

- ▶ **Simple maintenance**

application



Remove the dust collection canister without tools for easy dumping.



No-tools filter removal provides simplified filter maintenance.

How it Works

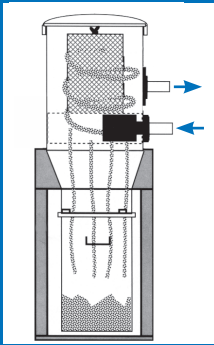

DC1 and DC2
Dust-laden vacuum air enters the collector, where the spinning air stream separates most of the dust. The oversized filter traps the remaining dust and collects the excess in the integrated canister. The "popper" valve closes at the end of the conveying sequence, rapidly changing the air pressure. This shocks the filter clean and allows fines to drop into the collection canister.

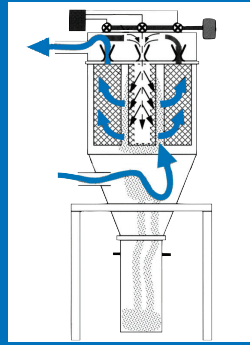

DC3 Super Dust Collector
Three filter cartridges collect the dust. A purging cycle uses accumulated compressed air to blast each cartridge clean from the inside out. This continuous adjustable sequence drops fines into the collection canister. The DC3 provides maximum filter life between manual cleanings.

Features

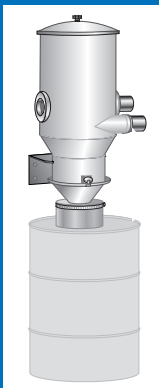

Auto-Dump option
automatically ejects the collected fines and dust at the conclusion of each vacuum cycle. The Dust Collector can be placed over an open drum or gaylord to receive fines. An elevated frame is recommended, or the DC1 and DC2 Dust Collector bodies may be wall mounted.

Applications

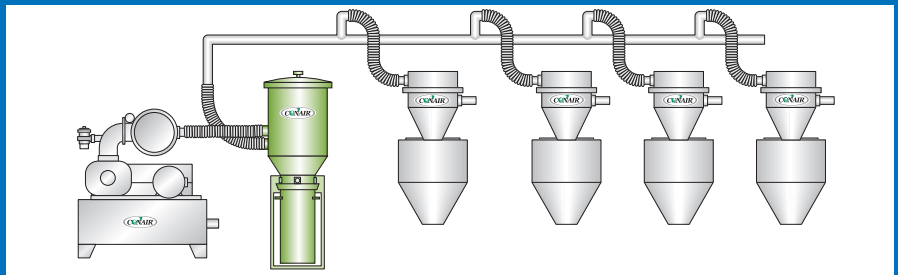

Typical installation- Screens in the vacuum receivers permit some fines to be passed back towards the pump. These fines are trapped in the central dust collector and collected in the integral air-tight canister. Typically, the collector is located near the vacuum pump.

Specifications

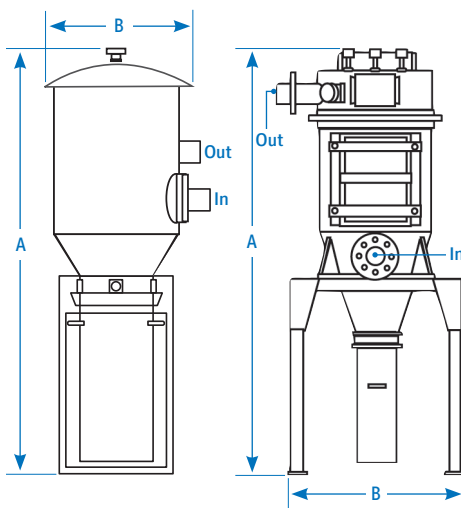

Model DC1 and DC2

Model DC3

Model	DC1	DC2	DC3
Performance characteristics			
Pump size range Hp {kW} *	3-7.5 {2.2-5.6}	10-25 {7.5-18.7}	3-25 {2.2-18.7}
Vacuum line size OD inches {mm}	1.5-2.5 {38.1-63.5}	2.25-4.0 {57.2-101.6}	1.5-4.0 {38.1-101.6}
Filter area ft ² {m ² }	42.8 {4.0}	100.3 {9.3}	162.0 {15.0}
Maximum collection capacity ft ³ {liters}	1.1 {31.1}	2.1 {59.4}	1.1 {31.1}
Recommended dust collection ft ³ {liters}	0.75 {21.2}	1.0 {28.3}	0.75 {21.2}
Dimensions inches {mm}			
A - Height	58.0 {147.3}	67.0 {170.1}	92.5 {235.0}
B - Width	23.0 {584.2}		36.5 {92.7}
Depth	23.0 {584.2}		36.5 {92.7}
Approximate weight lb {kg}			
Installed	110 {50}	150 {68}	545 {247}
Shipping	140 {64}	280 {127}	695 {315}
Compressed air requirements	80-120 psi {5.5-8.3 bars}		
Voltage Full load amps †			
120V/1 phase/60Hz	1.0	1.0	5.0
Efficiency	95% at 10 microns		

Specification Notes

* Model DC1 works with Conair pump models RG1-3, RG1-6, RG2-5, RG2-8, PSS3, PSS6, PD3, PD5, PD7.5, LDP5, LDP7.5. Model DC2 works with RG1-11, RG2-16, PSS11, PD10, PD15, PD25, LDP10, LDP15, LDP30. DC3 works with all sizes. DC3 is not recommended for use with Conair's LDP Series pumps.

† FLA data for reference purposes only. Does not include any options or accessories on equipment. For full FLA detail for power circuit design of specific machines and systems, refer to the electrical diagrams of the equipment order and the nameplate applied to the machine. Specifications may change without notice. Consult with a Conair representative for the most current information.

