



The Perfect Pump for industrial applications



THE PUMP OF CHOICE FOR INDUSTRY

The Sine pump principle



- Energy efficient pumping
- Gentle pumping action
- High suction capability
- Easy maintenance

Whether installing a new plant or seeking to replace your existing pump, MasoSine pumps offer the ideal solution for improving performance and minimising total cost of ownership.

The unique sinusoidal rotor design of the MasoSine pump ensures the safe and gentle handling of products with a viscosity of up to 8 million centipoise (cP). The Sine principle requires less power to operate in viscous applications. This means significantly lower energy usage compared to other pump types; reducing Carbon Dioxide emissions and helping to achieve greater sustainability.

Maintenance can be done in-place within minutes by a line operative. Replacing off-the-shelf wear components leads to “new pump” performance. There is no need for re-machining of the pump housing or using oversized parts.

All MasoSine SPS pumps carry a 20 year guarantee on the housing and front cover, proof our high quality standards. As the world leader in Sine pump technology, we provide unrivalled aftersales and local specialist support.

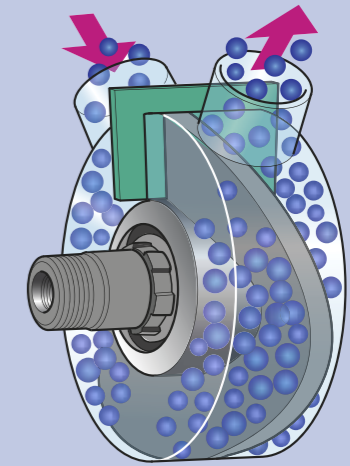

A single sinusoidal rotor in the pump creates four evenly sized chambers as it rotates within the pump. Fluid is “pulled” through the inlet on the suction side into each chamber in turn. As each chamber rotates, it contracts, closes and finally discharges fluid through the outlet port. At the same time, the opposite chamber opens to draw in more fluid. The result is a perfectly smooth flow, free of any pulsation.

A gate functions as a seal between the inlet and outlet sides of the pump. Preventing equalisation of pressure and stopping fluid escaping from the higher pressure outlet into the lower pressure suction side. The sinusoidal rotor rotates within two replaceable liners, ensuring no wear to either the pump housing or cover.

Sine pump advantage

Energy efficient pumping action – Reduce your energy costs and minimise CO2 emissions.

Gentle product handling – ultra low shear ensures continuity of product quality.

Superior viscous handling with lowest NIPR/NPSHR – powerful suction up to 0,85bar vacuum without running the pump under cavitation.

Simplicity – Minimal downtime. One shaft, one seal and no timing gears enable easy in-place pump maintenance in minutes.

Interchangeable parts – Fully interchangeable components between pumps of the same size, reducing spares inventory



FEATURES AND BENEFITS

Easy maintenance

- One shaft, one rotor and one seal. No complex timing gears
- Replace off-the-shelf wear components to restore to “new pump” performance
- Easy access for in-place cleaning and maintenance, requiring no special skills or training
- Parts are fully interchangeable between pumps of the same size, reducing spares inventory and simplifying maintenance procedures
- 180° powerframe mounting for easy drainage and maintenance

Virtually pulsation free

- Smooth product flow with no need for ancillary dampeners, ensuring process and product quality
- Flow meter accuracy is improved and heat exchanger performance is more efficient

Gentle handling of shear sensitive products

- Ultra low shear transfer of sensitive products
- Gentle pump action causes no aeration or foaming during product transfer

Superior viscous product handling

- Consistent flow with pressures up to 15bar (217psi)
- Viscous handling from 1 cP to 8 million cP without modification to the pump
- High suction capability up to 0.85bar



Flexible

- A range of eight pumps with flow of up to 99,000 l/hr
- Matched to the customer’s process requirements and duty fluid
- Port positions available to fit piping requirements, making drop-in replacement possible without changing existing pipework
- Pump can run clockwise or counter clockwise
- Stainless steel pump housing, cover and powerframe

Low cost of ownership

- Easy access to wear parts enables line side maintenance, completed in minutes by a line operative
- Up to 50% less energy usage for the same flow compared to other pump types

Efficiency

- Less energy consumption compared with other positive displacement principles, especially with highly viscous products
- Reduction of CO2 emission
- Reduction of total costs of ownership due to highly efficient pumping action

APPLICATIONS



◀ Liquid washing agents

MasoSine pumps stand out from competition for handling shear sensitive products like washing agents as well as a pumping principle that allows product transfer without foaming. Due to the foamless pumping principle the filling line can keep its accuracy and a high filling frequency.

- **Low shear with almost zero pulsation ensures a laminar flow and therefore gentle product handling, an important factor when handling delicate products such as liquid washing agents that are prone to shear and foam forming**



◀ Latex

If latex is exposed to mechanical forces it changes its viscosity and can create solids. Therefore the gentle handling is important to keep product quality high and reduce the risk of seal failure. MasoSine pumps are the perfect solution to keep the product's integrity.

- **Low shear with almost zero pulsation ensures a laminar flow and gentle product handling. This is ideal e.g. for pumping latex on a coating belt to avoid different thickness of the coating**
- **Availability of different seal systems and even customized seal systems helps to solve common seal issues**

Adhesives ▶

Gentle product handling for shear sensitive products like silicone. High suction capability to handle extremes of viscosity whilst reducing risk of cavitation in the system helps our customers to keep their production rate and product quality high.

- **Capability of handling high viscous products up to 8 million cP**
- **High suction capability to get high viscous products into the pump without running under cavitation due to very low NPSHR/ NIPR**



Liquid polymer ▶

Low energy consumption in operation is highly important, as is the ability to handle products with varying viscosities without the need for changing the pump setup. MasoSine pumps are the ideal for handling viscous products such as liquid polymer within waste water treatment applications.

- **High suction capability to get high viscous products into the pump without running under cavitation due to very low NPSHR/ NIPR**
- **The polymer is not subjected to any shear therefore the product maintains its integrity without any adverse effect to the fragile polymer chains**



TECHNICAL SPECIFICATIONS

Dimensions

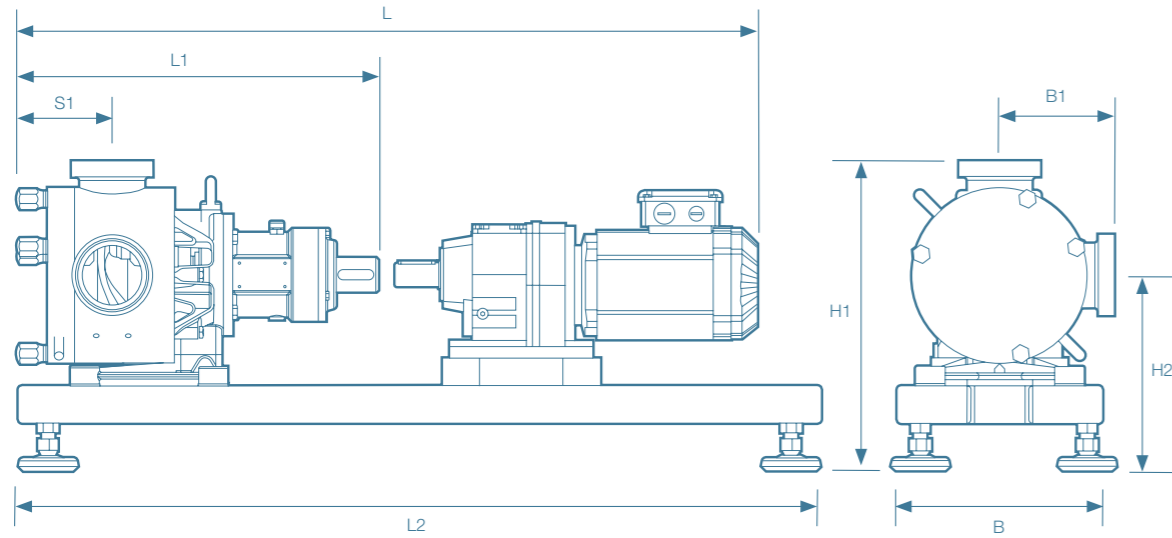

Model	L		L1		L2		S1		B		B1		H1		H2									
	min.	max.							min.	max.	min.	max.	min.	max.	min.	max.								
	mm	inch	mm	inch	mm	inch	mm	inch	mm	inch	mm	inch	mm	inch	mm	inch	mm	inch						
SPS 100	735	28.9	860	33.9	292	11.5	800	31.5	89	3.5	210	8.3	97	3.8	121	4.8	300	11.8	330	13.0	202	8.0	232	9.1
SPS 200	740	29.1	960	37.8	345	13.6	800	31.5	95	3.7	210	8.3	106	4.2	137	5.4	314	12.4	344	13.5	208	8.2	238	9.4
SPS 250	872	34.3	1,091	43	428	16.9	800	31.5	114	4.5	210	8.3	126	4.96	156	6.14	375	14.8	445	17.5	250	9.84	290	11.4
SPS 300	985	38.8	1,382	54.4	492	19.4	1,100	43.3	128	5.0	280	11.0	156	6.1	182	7.2	426	16.8	490	19.3	270	10.6	310	12.2
SPS 400	1,235	48.6	1,805	71.1	619	24.4	1,300	51.2	169	6.7	380	15.0	192	7.6	208	8.2	505	19.9	567	22.3	318	12.5	358	14.1
SPS 500	1,300	51.2	1,640	64.6	659	25.9	1,300	51.2	131	5.16	380	15	212	8.35	235	9.25	560	22	623	24.5	348	13.7	388	15.3
SPS 600	1,755	69.1	2,200	86.6	771	30.4	1,400	55.1	319	12.6	400	15.8	274	10.8	274	10.8	630	24.8	700	27.6	353	13.9	433	17.1
SPS 600L	1,302	51.3	2,100	82.7	686	27.0	1,400	55.1	234	9.2	400	15.8	270	10.6	274	10.8	675	26.2	757	29.8	390	13.4	487	19.2

Performance curves

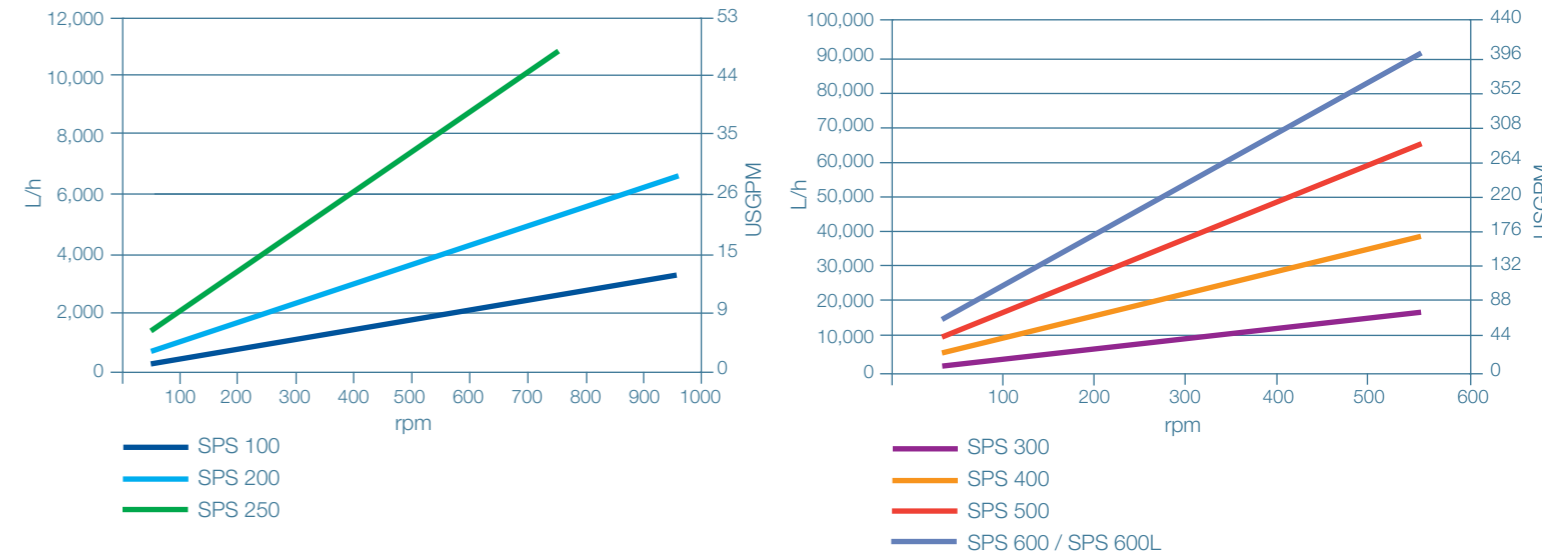

Technical data

Model	Maximum particle size		Volume per revolution		Speed	Maximum flow		Maximum pressure		Maximum temperature	
	mm	inch	litre	US gallons	rpm	l/h	US gal/min	bar	psi	C	F
SPS 100	10	0.39	0.08	0.021	1,000	4,800	21.1	10	145	180	356
SPS 200	20	0.79	0.13	0.034	1,000	7,800	34.2	10	145	180	356
SPS 250	22	0.87	0.24	0.063	800	11,520	50.5	15	217	180	356
SPS 300	30	1.18	0.50	0.132	600	18,000	78.9	15	217	180	356
SPS 400	48	1.89	1.16	0.305	600	41,760	183.2	15	217	180	356
SPS 500	50	1.97	1.92	0.505	600	69,120	303.2	15	217	180	356
SPS 600	60	2.36	2.75	0.724	600	99,000	434.2	15	217	180	356
SPS 600L	60	2.36	2.75	0.724	600	99,000	434.2	10	145	180	356
EC-25	22	0.87	0.24	0.063	800	11,520	50.5	6	87	95	200
EC-40	36	1.42	0.94	0.247	600	33,840	148.4	6	87	95	200
EC-60	60	2.36	3.74	0.984	600	134,640	590.5	6	87	95	200





Connection ports

MasoSine pumps are available with all standard ports to match your application including DIN, TC, SMS, ANSI. Customised options are available upon request.



Port orientation

Pumps can be configured with ports in a range of orientations to meet installation requirements. Customised port orientations are also possible upon request.

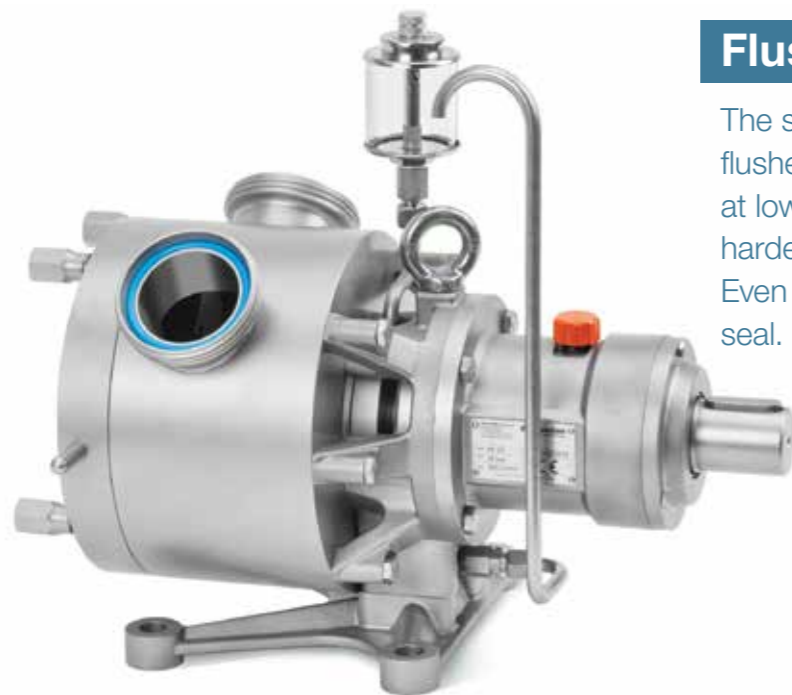

Flush systems

The static and dynamic flush system flushes the area behind the seal system, at low pressure, to prevent product from hardening and damaging the seal system. Even possible with a single mechanical seal.

Service

We believe in providing the highest standard of service to our customers, at every level. We work with them to understand their applications and pressures affecting their business, and provide solutions that are specifically matched to their requirements.

Support

Customer support is provided through a network of MasoSine pump specialists and technical support teams. This ensures our customers always benefit from local knowledge and MasoSine pump expertise. No matter where your business operates, MasoSine is never far away.

Genuine spares

MasoSine's approved parts policy means only the highest quality materials are used in the manufacture of our pumps. This gives our customers confidence that our pumps will not let them down. Essential spare parts can be despatched on the day the order is received. Standard pumps can be despatched within 24 hours.



Sustainability Curves



MasoSine Energy Efficiency (Mee) curves demonstrate how the sine principle requires less power to operate in viscous applications. The curves demonstrate clearly how MasoSine pumps help organisations achieve greater sustainability.



INDUSTRIAL SOLUTIONS



Watson-Marlow Fluid Technology Group

Watson-Marlow Fluid Technology Group supports its customers locally through an extensive global network of direct sales operations and distributors

wmftg.com/global

